

BODYCRAFT

X52





Dual-Stack Strength Training System

A Complete Health Club in One Small Package The BODYCRAFT X2 is efficiently designed to deliver the greatest variety of exercises in a multi-station gym. Built to the highest specifications, the X2 is perfect for multiple user environments as well as homes. Every detail has been well thought out, from the comfortable ergonomics, to the top-of-the-line components that ensure rugged wear and smooth performance. Every strength training need is built into the X2, including traditional machine training, cable training, and functional training. A truly versatile machine at an affordable price!

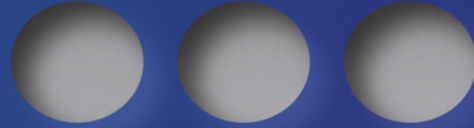

Exercise charts are easy reference and permanently mounted to steel plates on all four sides. Pictures and descriptions of 40 different exercises show proper positioning and form and the muscles worked.

Leg Press / Calf Raise Station has an adjustable, contoured back to accommodate all sizes. The fixed foot plate pivots on industrial pillow block bearings for long lasting, smooth operation. Selected weight ratio is 1:2 for up to 400 pounds of resistance.

High Pulley Station
For lat Pulls, Triceps Push Down and More!

Ab Crunch / French Curl
Station for strengthening and shaping abdominal muscles. Can also be used for Triceps Extension (French Curls).

Easy Adjusting Functional Training Arms provide a complete range of exercises equivalent to a full set of dumbbells. Adjust the Cable Arms to the lowest position for Arm Curl, Lateral Raise, Front Raise, and Shrugs. Rotate the Arms to a middle position for Pec Flys, Incline Press, and all Dumbbell Style (converging) Presses. Adjust the Cable Arms to the top position for Shoulder Press. These unique Cable Arms also provide for Functional Training and Rehabilitation type exercises. Over 50 different exercises on this station alone!

Press / Pull Station has range-of-motion adjustments to fit all size users and to provide more variety. Exercises available on this station include Bench Press, Incline Press, Shoulder Press, and Mid Row.

Low Pulley Station with foot plate provides a variety of exercises not limited to: Low Row, Upright Row, Arm Curls, Hip Adduction, Hip Abduction, and Glute Kicks.

Leg Extension / Curl for targeted leg development. Provides Seated Leg Extensions, Standing Leg Curls.

Warranted for multi-user environments

The Bodycraft X2 borders on nearly an infinite number of exercise possibilities. Incorporated into one of the 4 exercise stations are innovative functional training arms that allow for almost any angle of movement. Below are a few examples of exercises but is truly only limited by your imagination.



Chest Press



Incline Pec Fly



Shoulder Press



Glute Kick

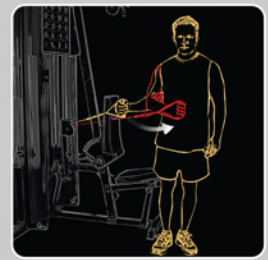

Internal Rotator



Oblique Twist

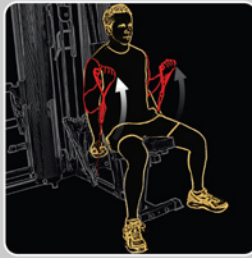

Arm Curl



Hip Abduction



Lunge



Triceps Kickback



Overhand Throw

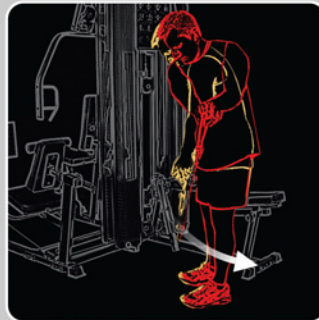

Golf Swing

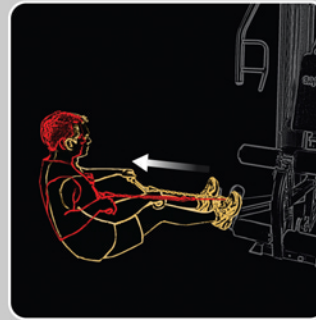

Low Row



Leg Extension

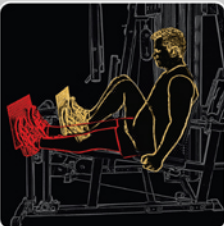

Leg Press



Lat Pull Down



Ab Crunch

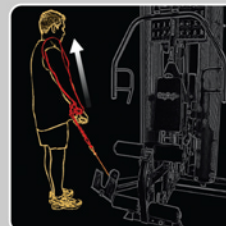

Shrugs

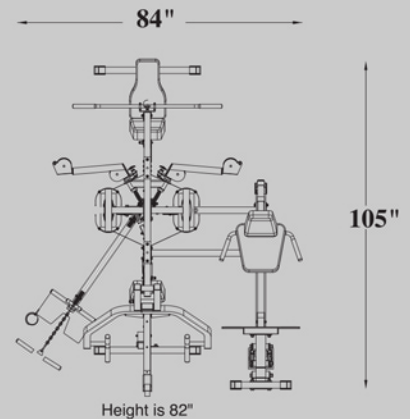

SPECIFICATIONS

Frame: 2" X 3", and 2" X 2", 11-gauge and 12-gauge steel tubing. Finish: Platinum Gray multi-stage electrostatic powdercoat paint.

Pulleys: 4-1/2" diameter, fiberglass reinforced nylon and rotate on sealed ball bearing hub.

Cables: Internally lubricated, 7 X 19 strand construction, rated at 2000 pound tensile strength.

Upholstery: Double-stitched heavy gauge vinyl covering contoured, extremely-dense foam.

Weight Plates: 1-1/4" thick precision milled with EZ Glide nylon bushings.

Accessories: Lat Bar, Curl Bar, 2 Single Handles, Ankle Strap, Ab Crunch Strap, 4 Exercise Charts and Exercise DVD.

In Home Lifetime Warranty: Every part of the X2 is guaranteed for as long as you own it. We will replace or repair any defect. Warranty applies only to the original owner and for in-home use.

Light Commercial Warranty: The X2 is warranted for light commercial use for a period of 2 years. This warranty applies to all parts. The framework is warranted for as long as the original owner owns it.